



PRODUCT FEATURES

- 3 HP Induction motor
- Belt driven permanently lubricated transmission
- Heat-treated hardened steel alloy gears and shafts
- Three fixed speeds
- Thermal overload protection
- Rigid cast iron body
- 60 litre stainless steel bowl
- Removable stainless steel bowl safety guard with built in ingredient chute
- Safety interlocked bowl guard and bowl lift Front mounted controls
- 15 minute analogue timer
- Non-slip rubber feet
- 1.8m cord no plug supplied

STANDARD ACCESSORIES

- | | | |
|-----------------------------------|-------|--------------|
| • 60 litre bowl (stainless steel) | Ref # | SP60-32 |
| • Beater (aluminum) | Ref # | SP60-30 |
| • Whisk (stainless steel) | Ref # | SP60-31 |
| • Dough hook (aluminum) | Ref # | SP60-29 |
| • Bowl Trolley with handle | Ref # | Trolley/60-N |

OPTIONAL ACCESSORIES

- | | |
|--------------------------------------|------------------|
| • 30L Reduction Kit w/tools | Ref # ACC30/SP60 |
| • Reinforced Whisk (stainless steel) | Ref # 60031-A |
| • Bowl Scraper | Ref # SP60/SCRP |

TECHNICAL DATA

| | |
|---------------------------|--------------------------------|
| Power | 3 HP |
| Electrical data | 415V/50/3 Draw 5.8 Amps |
| | Three Phase - no plug supplied |
| Speed | 3 speed - 99 / 167 / 329 rpm |
| Dimensions (LxWxH) | 778 x 638 x 1316 mm |
| Gross weight | 270 kg |
| Reference | SP60-S |

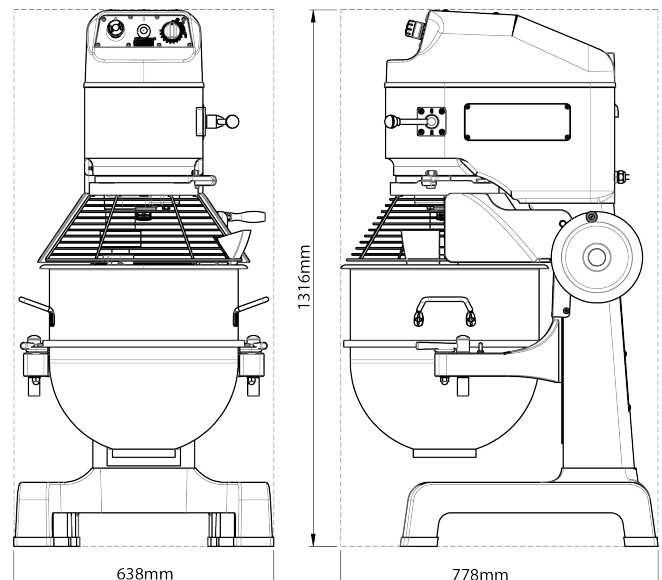
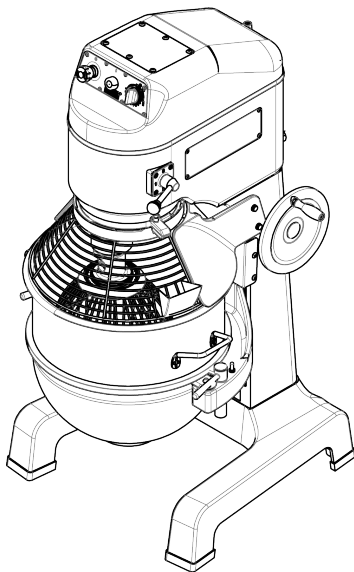

STANDARDS

